

BIOLAN



BIOLAN GREYWATER FILTER light

Instructions for installation, use and maintenance

EN

Serial No.	
Assembler	Date of manufacture
Seller's stamp, signature and date of purchase	

27722000

11/2012

BIOLAN

Fig. 1

Installation example and dimensions when connecting in series

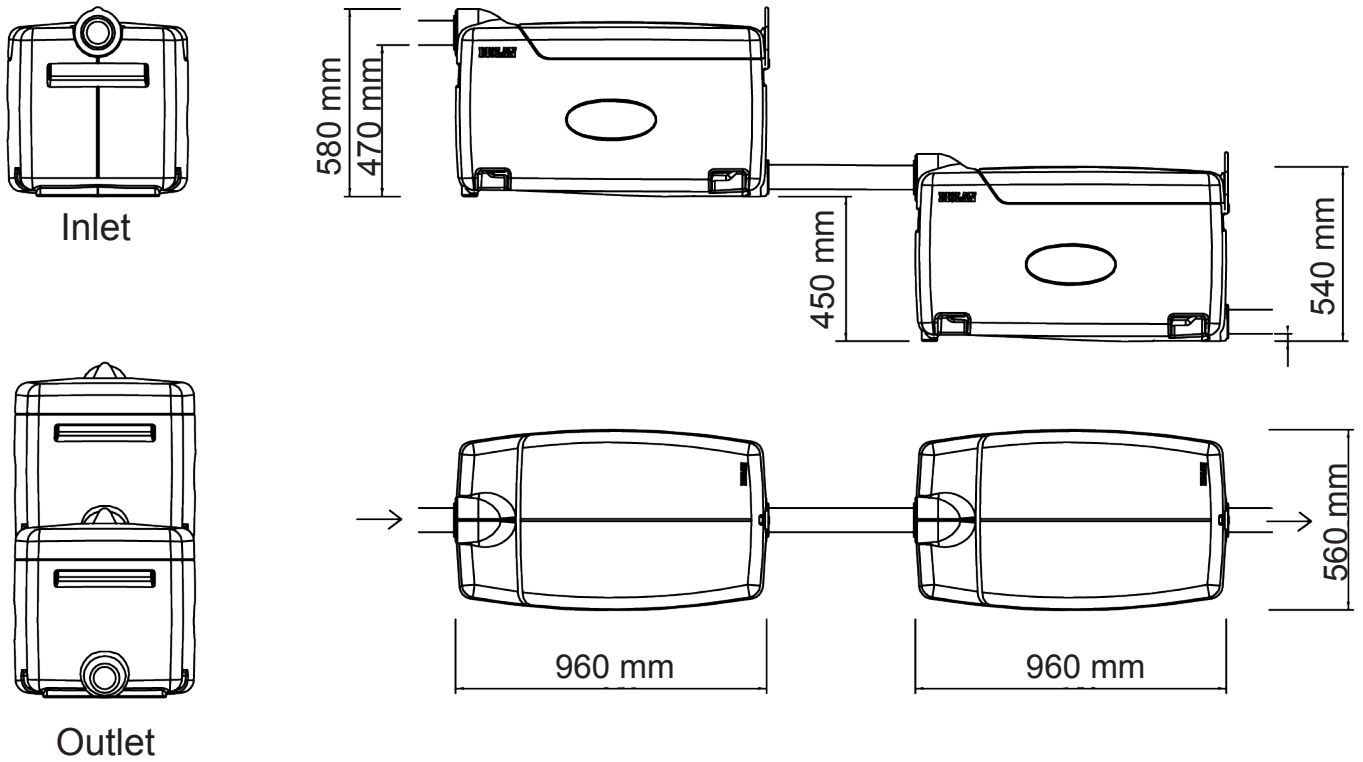
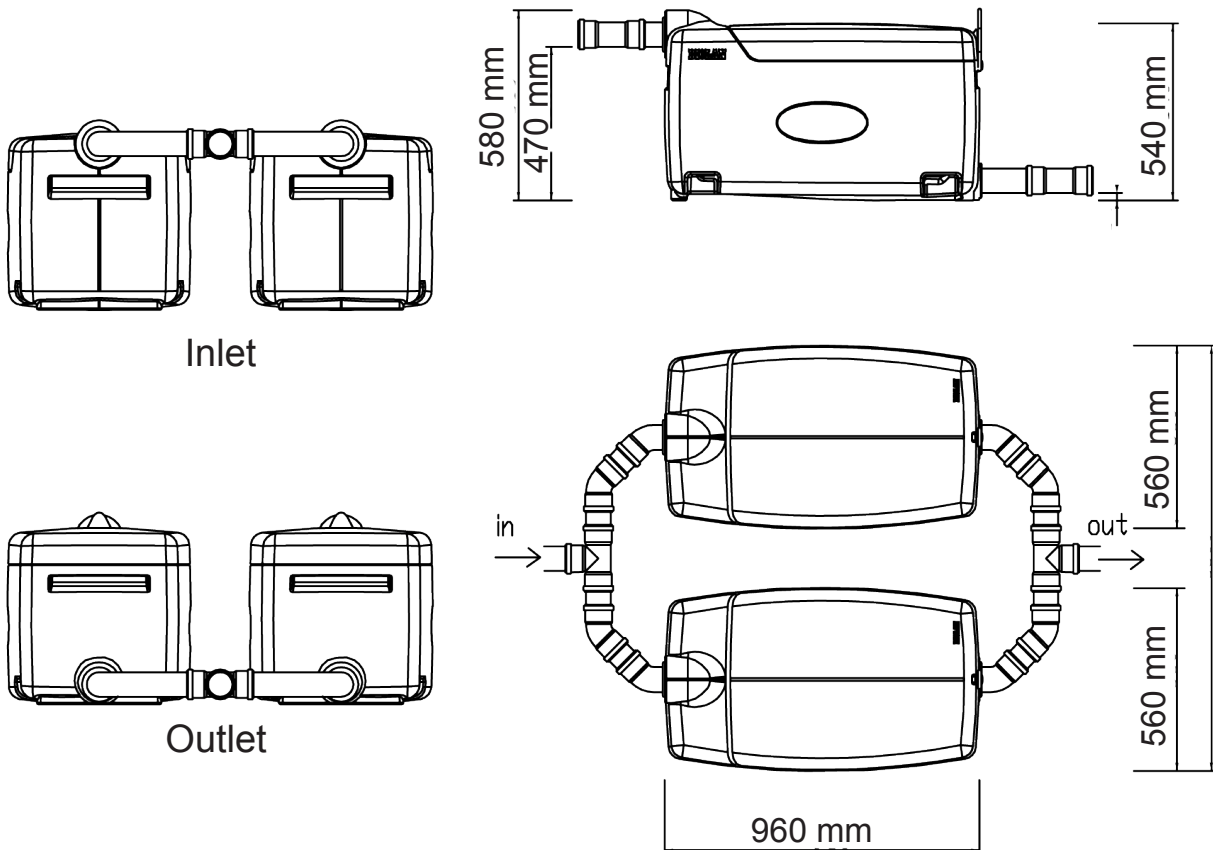

Fig. 2

Installation example and dimensions when connecting in parallel



BIOLAN GREYWATER FILTER light

Instructions for installation, use and maintenance

Biolan Greywater Filter light is a non-insulated filter module for washing water. The filter module, or a treatment system made up from modules, is suitable for outdoor installation at locations used only in summer, such as a summer cottage, or a cottage at an allotment garden. These modules can also be used year-round, provided that they are located in a space where the temperature stays above zero at all times. The wastewater is routed directly into the modules by gravitation or by pumping – no septic tanks required. The treatment capacity of one module is about 300 litres per day.

Contents

Component list	EN-2
Component drawing	EN-2
1. Planning and installation	EN-3
1.1 Technical specifications	EN-3
1.2 Locating out of doors	EN-3
1.3 Location inside a residential building	EN-3
1.4 Air circulation	EN-3
1.5 Conducting wastewater to the filter	EN-4
1.6 Discharge point for wastewater	EN-4
1.7 Putting the filter material in place	EN-4
2. Use and maintainance	EN-4
2.1 Follow-up of the operation	EN-5
2.2 Changing the filter material	EN-5
2.3 Storing the filter over winter	EN-5
3. Possible malfunctions	EN-5
3.1 The filter box is constantly filled with water	EN-5
3.2 Flies in the filter	EN-5
4. Disposal of the product	EN-5
Biolan accessories	EN-6
About the guarantee	EN-6



EN

Component list

	Part name	Number	Material
1	body	17722201	PE
2	top	17722202	PE
3	filter box	17715050	PE
4	ventilation pipe cap	18710250	PE
5	pipe 75 x 220 mm	28704050	PE
7	branch sleeve 75 / 75 mm	28733120	PP
7	pipe 75x385 mm with sleeve	28704051	PE
6	inlet pipe end	18715250	PE
9	latch	18710370	EPDM
10	washer for latch	18726140	PE
11	lead-through rubber 75 mm, black	18001001	EPDM

In addition to the components illustrated in the components picture, the Greywater Filter light also includes:

	crosshead screw M5x25 A4	20040026	RST
	nut nylock M5	20020009	RST
	fender washer A2 M5	20060002	RST
	sealing band 12*4mm, 2,5 m	19776001	EPDM cell rubber
	lifting handle	18722003	PE
	plug 75 mm	18715130	PE
	user manual Finnish/Swedish	27722000	PAPER
	user manual in 10 languages (export products only)	27723000	PAPER
	Filter material	70574100	

Spare parts sales: dealers in Finland and the Biolan online shop at www.biolan.fi

Component drawing

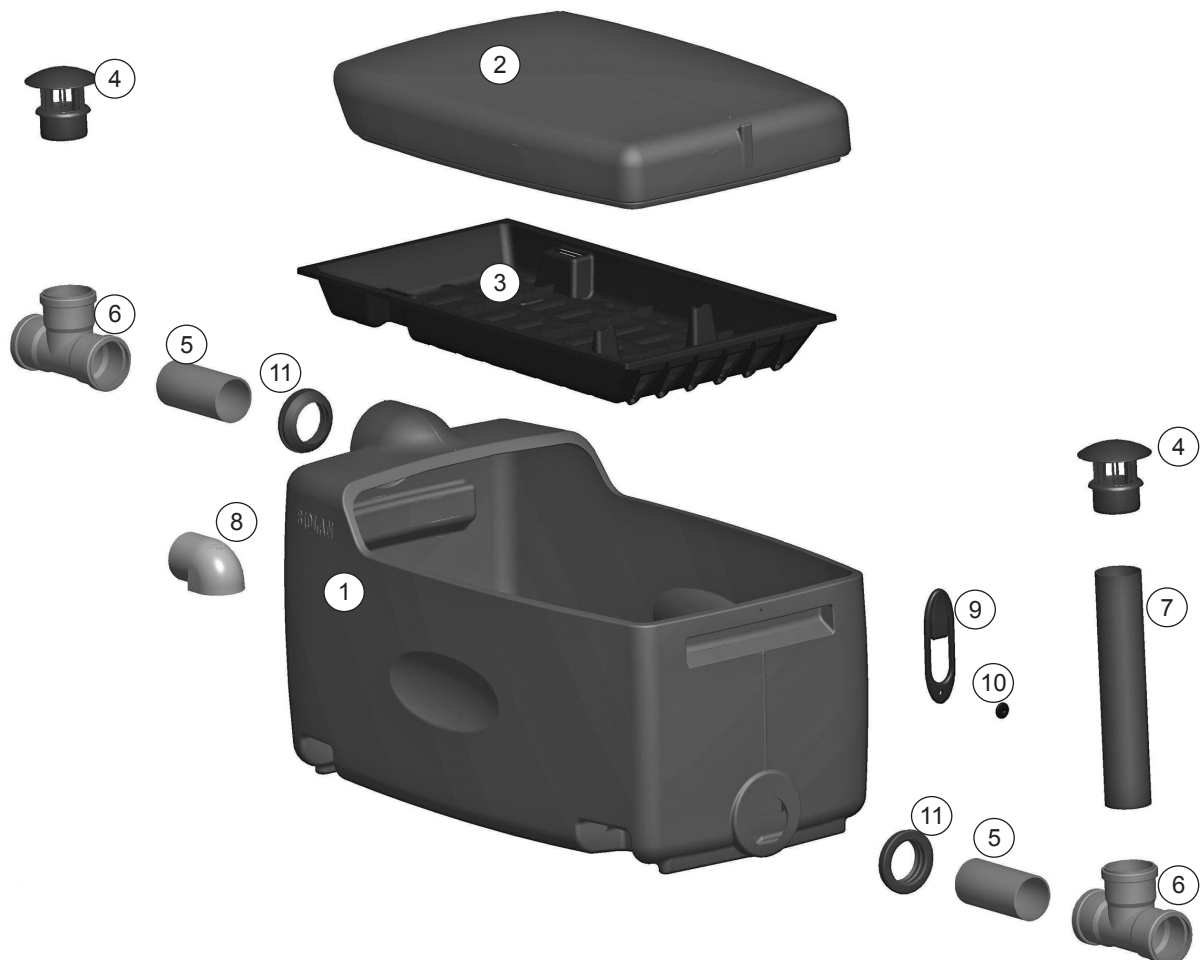

1. Planning and installation

The operation of the Biolan Greywater Filter light is based on the mechanical and biological filtration of wastewater. The dirt in the wastewater sticks to the organic filter material in the filter. The micro-organisms living on the surface of the material use the impurities in the water as their nutrition.

The module contains five filter boxes placed one on top of the other. The wastewater is conducted into the uppermost filter box. Inside the filter, the wastewater flows nearly horizontally by gravitation from one filter layer to the other through the openings in the end of the box.

Wastewater from a WC or dry toilet in the property must be conducted into a closed tank or treated otherwise in a due manner. Rain- or stormwater or drainage water from foundations must not be fed into the filter. The cleaning capacity of the filter material in the module is good for about 100 days, after which it should be replaced in accordance with the maintenance instructions.

Place the filter on a firm and even surface that is not susceptible to frost, such as, for example, a bed of gravel or crushed stone or a cast concrete slab. The filter must be in a horizontal position both lengthwise and laterally to allow the wastewater to flow smoothly over the entire cleaning area of the filter material.

1.1 Technical specifications

- dimensions of the module: (width x height x depth) 560 x 580 x 960 mm
- two modules installed in parallel: width about 1,300 mm
- two modules installed in series: min depth about 2,030 mm
- pipe connectors for Ø 75 mm sewer pipes
- height difference of inlet and outlet connectors is 450 mm (height of fall)
- capacity of the module: about 300 litres per day
- the distance, travelled by water in the filter material: about 325 cm
- weight without the filter material: 24 kg
- change of filter material: about every 100 days of operation

1.2 Location out of doors

The Biolan Greywater Filter light shall be installed above ground or buried partly in the soil. If the unit is buried in the ground, a ground support shall be built around it to take the pressure of the surrounding soil. Place the filter in a location where water will not gather, even when there is flooding. The filter can be installed out of doors without a cover. The unit has no thermal insulation. If the unit is used also in winter, it must be located in a space where the temperature stays above zero at all times.

1.3 Location inside a residential building

If you are planning to install the filter indoors or in close proximity to a residential building (for example, under the terrace), then some maintenance space with its own entrance should be provided.

This space must also be provided with a floor well or an earthen floor for possible malfunctions.

1.4 Air circulation

The operation of the filter is based on activity of the micro-organisms. These micro-organisms need oxygen to survive, and therefore, it is vital to provide the filter with sufficient air exchange. To ensure this, the module delivery includes two T-branches with which the air exchange system can be realised. A prerequisite for efficient natural ventilation is a height difference between the air inlet and outlet (from bottom to top), and possibly also a temperature difference (from colder to warmer).

The replacement air for the filter is routed from the end of the discharge pipe or via the air pipe that rises from the discharge pipe to above the ground surface. The outlet air from the filter located out of doors shall be routed as sewer ventilation to the roof or via an air pipe in the incoming sewer to the yard area. The outlet air from a filter located indoors or in immediate proximity to a residential building shall be routed as sewer ventilation to the roof of the building.



In Finland, building a wastewater system or changing it in locations with pressurised water always requires a building or action permission from the municipal building authority or a submission of notification of action. The building permission is applied by submitting a relevant plan.



A properly dimensioned, installed and operated Biolan Greywater Filter light wastewater system meets the requirements of decree (209/2011) of the State Council of Finland on the treatment of domestic wastewater outside the sewer systems of the water authority.



Whenever the Greywater Filter is located in a warm space in a residential building, or in close proximity to a residential building, the correct installation must always be verified with the expert in charge of planning the HVAC system for the building.

1.5 Conducting wastewater to the filter

The wastewater is conducted directly to the filter alternatively by gravity, by flow drainage or by a pump well. When installing flow drainage sewers, must be provided a sufficient gradient (of at least 1-1,5 %) to enable the wastewater to flow without obstruction from the sewer outlet of the house all the way to the discharge point. No septic tank required.

The module is fitted with inlet and outlet connectors for a 75 mm sewer pipe. The inlet connector is located at the upper edge of the module, and the outlet connector at the lower edge. It is possible to connect two modules in series or in parallel.

Serial connection

The sewage pipe coming out of the building is connected to the first module. The outlet pipe of the module is connected to the inlet connector of the other module. From the second module, water is routed to the discharge point in the usual manner (see page 2, Fig. 1).

Parallel connection

Wastewater is divided into two flows by means of a branch sleeve (see page 2, Fig. 2). To ensure an even distribution, the inlet pipe should be provided with a straight 80cm-long part before the branch sleeve, to reduce the turbulence of the incoming water flow.

Connecting four modules together

Wastewater flow is divided into two modules connected in parallel, after which two more modules have been installed in series.

Using existing septic tanks

If you intend to utilise existing septic tanks in your wastewater system, these should be in good condition and hermetically sealed.

Pumping wastewater to the filter

The operation of the pump must be sequenced using a timer so that during one sequence, the pump will feed at maximum 20 litres of wastewater to the filter. If the wastewater system consists of only one module, the recommended pumping rate is 10 litres. The Biolan Timer, the Submersible Pump and the Pump Well are available as options.

1.6 Discharge point for the wastewater

Route the treated wastewater to a suitable discharge point, for example a stone pocket, an infiltration pit or an open ditch. When planning, bear in mind that the discharge of wastewater should be unobstructed even when the level of the surface water or groundwater is high. If you route the water to an open ditch, provide the end of the pipe with a flap or a net to prevent rodents or other small animals from gaining access.

1.7 Putting the filter material in place

The filter material is packed in a bag inside the unit, and is distributed from the bag into the boxes. Rip the material loose and spread it evenly across the box by tapping it gently.

Finally, draw the filter material about 5 cm to the rear from the V-openings in the discharge end of the box.

The filter boxes are stacked firmly one on top of the other, inside the filter, each one pointing in the opposite direction to the previous one:

- discharge openings of the lowermost box (V-openings) on the discharge sewer's side
- discharge openings of the second lowest box on the inlet sewer's side

In this case, water circulates through all of the boxes before being discharged.

2. Use and maintenance

The unit must be used and maintained in accordance with the instructions, and its operation must be monitored regularly. Maintenance of the wastewater system also involves maintenance of the pump well and the septic tanks, if any.

The filter tolerates a small amount of anti-bacterial or chlorine-based agents that are commonly used for cleaning. Follow the dosing instructions issued by the manufacturer of the detergent.

Wastewater from a WC or a dry toilet, rain water or stormwater, or drain water from foundations must not be fed into the filter. Toxic chemicals or substances that contain such chemicals, which can kill the micro-organisms that clean the wastewater, such as drain openers, paints, oils or solvents, must not be fed into the filter. Harmful chemicals can be identified from the markings on their packaging:

Toxic



Corrosive



Hazardous to the environment



Inflammable



Oxidizing



2.1 Follow-up of the operation

Check the operation of the filter at least twice during every operating season. A well-functioning filter does not give off a strong smell, the filter material in it remains moist and the exiting water is clear and odourless and does not contain a significant amount of solid matter.

Check that

1. wastewater is flowing smoothly from all the openings of the box
2. the filter material has been drawn to a distance of about 5 cm from the openings in the discharge end of the box
3. the visible connections of the sewers are in order
4. the purified wastewater is flowing freely out of the filter

2.2 Changing the filter material

Normally, the filter material of the filter must be replaced every 100 days of operation. As filter material shall be only used special material, intended for use in the Biolan filters. Biolan Oy does not guarantee the purification capacity of the unit if any other filter material is used.

1. Change the filter material in all of the boxes at the same time.
2. Open the cover of the filter and lift the filter material boxes out of the unit by the lifting handles.
3. Empty the filter material into the compost or use it as cover soil for ornamental plants.
4. Refill the boxes with new filter material. Rip the filter material loose and spread it evenly across the box by tapping it gently. Finally, draw the filter material about 5 cm to the rear from the V-openings.
5. Check the inlet and outlet connectors for wastewater and clean them.
6. Return the boxes filled with filter material to the filter unit. The filter material boxes are identical, but their direction should be observed – in the lowermost box water flows towards the outlet connector, in the next box it flows towards the inlet connector etc.
7. Make sure that the unit is in a horizontal position both lengthwise and laterally so that wastewater flows smoothly from one box to the next.
8. Close the cover of the filter carefully.
9. Write down the service measures that you took.

2.3 Storing the filter over winter

Leave the filter material boxes inside the unit. Freezing of the filter material does not damage the unit. If the filter material is still frozen when the operation starts in spring, thaw it by pouring warm, clear water through the filter.

3. Possible malfunctions

3.1 The filter box is constantly filled with water

1. The filter box shall drain off between the times of operation. If this is not the case, the filter material may be clogged.
2. Make sure that the filter material has been drawn to a distance of about 5 cm from the openings in the discharge end of the box. As necessary, push the filter material slightly to the rear.
3. Check the age of the filter material. In heavy and continuous use, the filter material may get clogged already during the first 100 days of operation. Replace the filter material, if necessary.

3.2 Flies in the filter

The pipe caps delivered with the Greywater Filter are fitted with fly nets of small mesh size. Despite the nets, small flies or gnats may sometimes establish themselves in the filter. If flies are interfering with the filter, you can do away with them using a pyrethrin-based insecticide. Consult your local garden centre to select a suitable product.

4. Disposal of the product

The raw materials used are presented in the component list (page EN-2). Dispose of each part as prescribed. Always follow the regional and collecting-point-specific instructions.



PE = polyethylene
to collection of energy waste or recycling of plastic



PP = polypropylene
to collection of energy waste or recycling of plastic

RST = stainless steel
to recycling of metal

Paper
to recycling of paper

EN

Biolan accessories

Availability varies from country to country. Consult your local dealer for details.

Biolan Filter Material

The filter material for the Greywater Filter is made of Warnstorfia or Calliargon moss collected in connection with restoration of lakes. The moss, which has grown under conditions rich in nutrients, makes an efficient and natural material for purification of waste water.

Product no. 70574100,



Biolan Sampling Well

The Biolan Sampling Well is an accessory that makes it easier to supervise the operation of the wastewater treatment system, and enables reliable sampling of the wastewater. It is also suitable for an underdrain well or a pump well.

Product no. 70577800



Biolan Pumping Package

The Biolan Pumping Package is an accessory for places where gravity flow drainage of the wastewater to the filter is not possible. By means of the Timer the wastewater is fed from the Pump Well to the filter in suitable doses. The Pumping Package comprises three parts: Timer, Submersible Pump and Pump Well.

Product no. 70577300,



The parts are also available separately.

Comprises:

Timer, Product no. 70577000,

Submersible pump, Product no. 70577100

Pump Well, Product no. 70577200

About the guarantee

The Biolan Greywater Filter light is guaranteed for five years.

1. The guarantee is valid from the date of purchase and covers possible defects in material and workmanship. The guarantee does not cover any indirect damage.
2. Biolan Oy retains the right to decide about repairing or replacing damaged parts at its discretion.
3. Any damage resulting from careless or forcible handling of the device, from failure to observe the operating instructions, or from normal wear, will not be covered by this guarantee.
4. The buyer must present a duly filled out guarantee certificate or a detailed purchase receipt when submitting claims under the guarantee.

For matters related to the guarantee, please consult Biolan Oy directly.

BIOLAN

Biolan Oy

P.O. Box 2, FI-27501 KAUTTUA

Tel. +358 2 5491 600

www.biolan.fi